

OFFICE/RETAIL · 1,300 SQ FT **FOR LEASE**



**HARSHMAN**  
PROPERTY SERVICES  
COMMERCIAL REAL ESTATE

**HORNET PROFESSIONAL BUILDING**  
3850 S. Emerson Avenue · Suite E  
Indianapolis, IN 46203

Small Office  
Space Close  
to I-465 S in  
Beech Grove

1,300 SQ FT **FOR LEASE**



## OVERVIEW

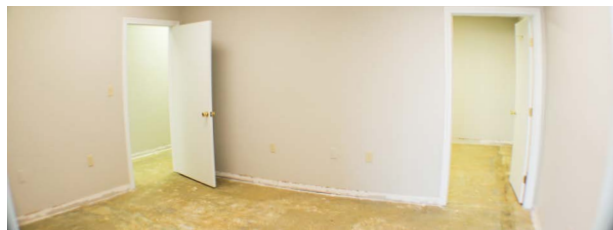

## ABOUT THE PROPERTY

- Professional services offices available
- Monument signage advertising
- Good drive-by visibility on high-traffic
- Emerson Avenue, just north of I-465
- Other professional tenants include: doctor's office and tax service.
- Ample parking
- Exterior and parking lot lighting
- Professionally managed
- Only 8 miles from downtown Indianapolis

Contact me for more  
information **TODAY!**

**KRAIG DOWNHAM**  
M :317.648.2100  
E : kraig@harshmanonline.com

9235 Crawfordsville Road  
Suite 5  
Clermont, Indiana 46234

OFFICE/RETAIL · 1,362 SQ FT FOR LEASE

3850 S. Emerson Avenue · Suite E  
Indianapolis, IN 46203



## PROPERTY DEMOGRAPHICS

Population	1 Mile	3 Mile	5 Mile
2019 Total Population:	11,484	72,918	213,674
2024 Population:	11,684	73,893	217,965
Pop Growth 2019-2024:	1.74%	1.34%	2.01%
Average Age:	36.70	36.70	36.30

Households	1 Mile	3 Mile	5 Mile
2019 Total Households:	4,749	27,678	82,474
HH Growth 2019-2024:	1.73%	1.25%	1.87%
Median Household Inc.:	\$42,988	\$49,253	\$45,657
Avg Household Size:	2.40	2.50	2.50
2019 Avg HH Vehicles:	2.00	2.00	2.00

Housing	1 Mile	3 Mile	5 Mile
Median Home Value:	\$113,952	\$127,723	\$129,689
Median Year Built:	1974	1971	1963

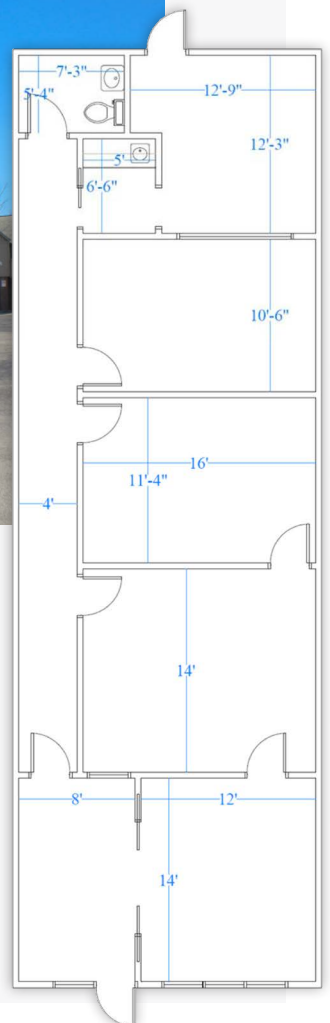

## TRAFFIC VOLUME 2018

Collection Street	Cross Street	Traffic Volume	Dist from Subject
Emerson Ave	S Emerson Ave	23,133	0.04
Elmwood Ave	Emerson Ave	10,750	0.34
S 1st Ave	Lifegate Way	22,479	0.35
Emerson Ave	Elmwood Ave	22,687	0.37
Elmwood Ave	S Butler Ave	12,706	0.38
I- 74	Emerson Ave	13,919	0.44
Churchman Ave	S 4th Ave	15,476	0.46



**KRAIG DOWNHAM**

Broker

317.648.2100

kraig@harshmanonline.com